

# JA Standard Module Packaging Introduction

For JAM5(L)-72 and JAM/P 6-60 Series products  
728Pcs./Container  
2012 V1.0

**JA**SOLAR

[www.jasolar.com](http://www.jasolar.com)

SHANGHAI JA Solar Technology Co., Ltd.

Add: E6-E8 Plot, Minhang Export Processing Zone, Feng Xian District Shanghai , 201401, China

Tel: +86-21-3718 1000

Email: [service@jasolar.com](mailto:service@jasolar.com)

**JA**SOLAR

## Note:

This introduction is only for the JA Standard Module Packaging. All information is based on the following series module packaging:

**JAM5 (L)-72 Series**

**JAM6-60 Series**

**JAP6-60 Series**

JA Solar reserves the right to make changes to the packaging specification without prior notice.

## 1. Basic Knowledge

### 1) Dimensions and Weights of the modules

Module Type	L(mm)	W(mm)	H(mm)	Weight(kg)
JAM5(L) -72 Series	1580	808	40	15
JAM/P 6-60 Series	1650	991	40	18.5

### 2) Dimensions of the vertical packaging(26pieces ) (Only for reference)

Module Type	L(mm)	W(mm)	H(mm)	Module QTY Per Pallet	Gross Weight Loaded Pallet(for reference)
JAM5(L) -72 Series	1635	1140	980	26 pieces	440 kg
JAM/P 6-60 Series	1695	1140	1160	26 pieces	530 kg

### 3) Quantities of the modules

Module Type	Pallet QTY Per Container	Module QTY Per Pallet	Total Module QTY	Container Type
JAM5(L) -72 Series	28	26	728	GP
JAM/P 6-60 Series	28	26	728	HQ

## 2. Packaging Steps for 26-pieces packages

### 1) Layup the Plywood pallet

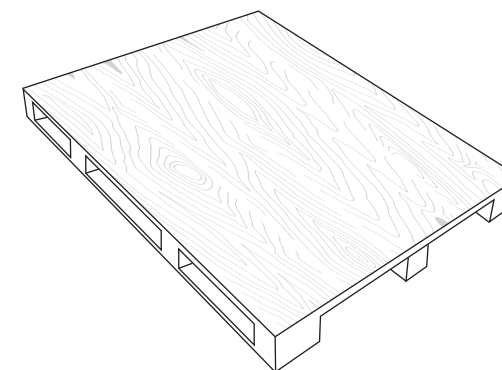

### 2) Put the hardboard corner to the modules: corners of interval modules will be covered with cardboard.

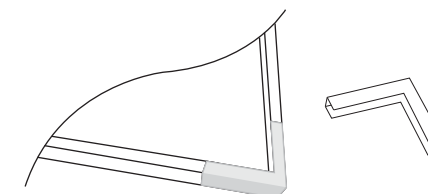

3) Put the modules to the pallet:  
For JAM5(L)-72 and JAM/P6-60 Series products,  
modules with protective corners and without corners  
are placed alternately.

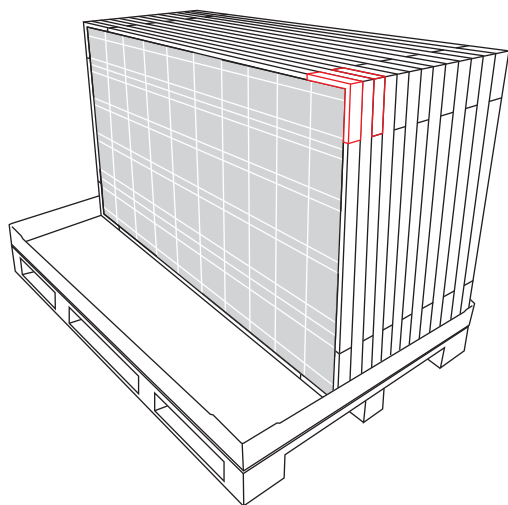

4) Put the long hardboard corner to protect the edges  
of the module.

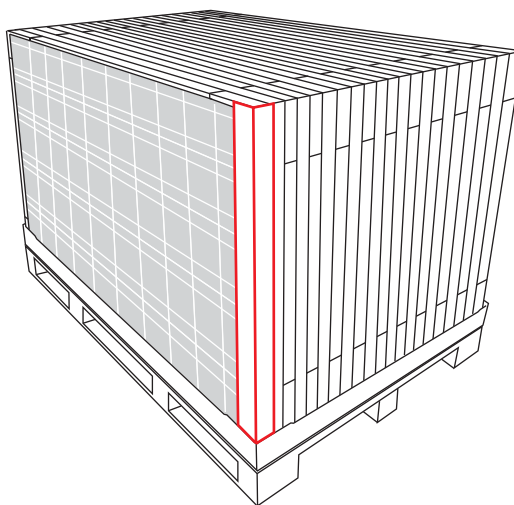

5) Put the cardboard box surround the package.

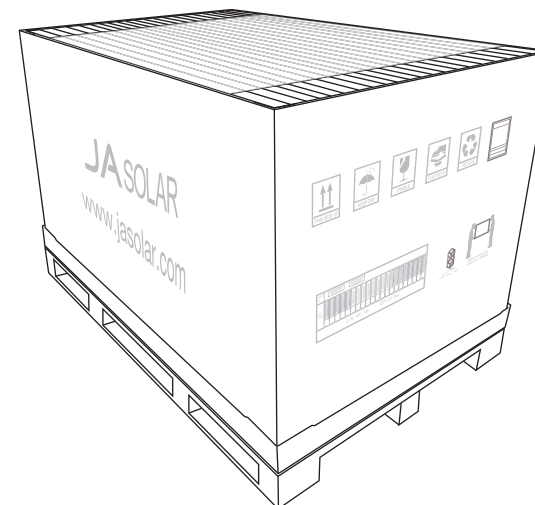

6) Cover the cardboard top above the package

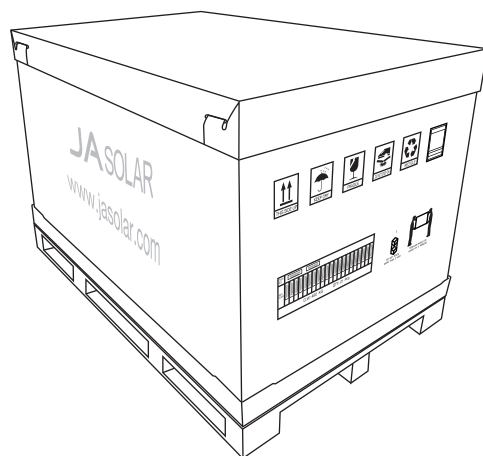

7) Stick the Label and Bar Code:  
The following gross weight and module QTY are different from different module types.

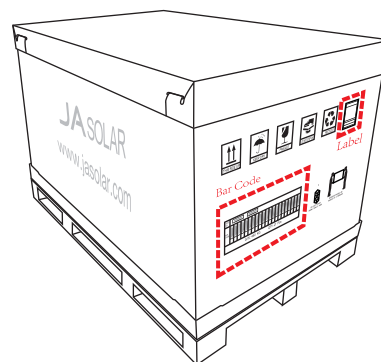

8) Use the strapping band to fix the package

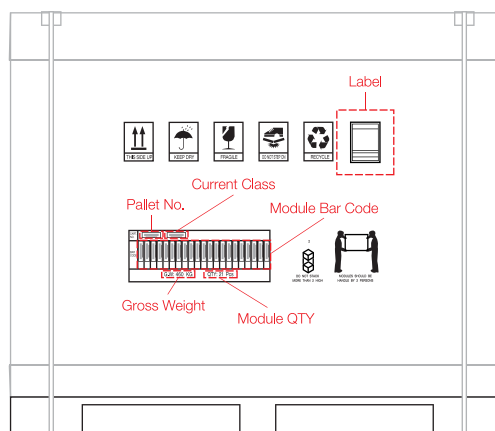
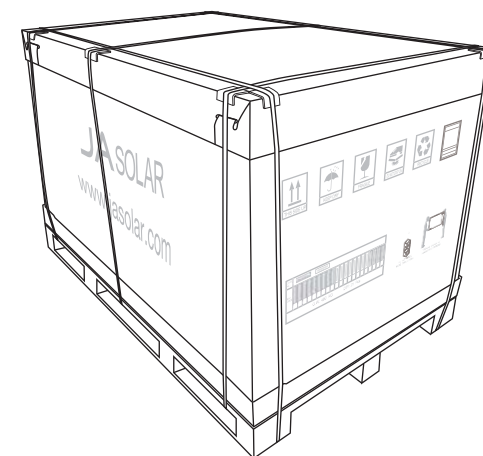

9) Use the wrapping film to cover the whole package

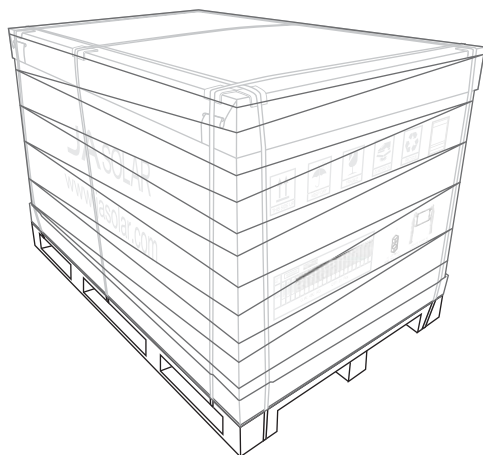

### 3. The combined mode of the packages.

The horizontal type package is fixed to the top of a vertical type package. Then they are piled up to another vertical package.

