

User Manual

GOODWE SS SERIES
Ver 01











Table of Contents

1 Symbols	01
2 Safety	02
3 Installation	04
3.1 Mounting Instruction	04
3.2 Unpacking	04
3.3 Equipment Installation	06
3.4 Electrical Connection	09
3.5 Troubleshooting	20
4 System Operation	24
4.1 Display	24
4.2 Indicator Lights	24
4.3 LCD display	25
4.4 Error Message	31
4.5 ID Reset	33
5 Technical Parameters	35
GW1500-SS GW2000-SS GW3000-SS	35
GW4000-SS GW4600-SS	38
GW3600S-UK/DK	41
6 Certificates	44
7 Warranty	45
7.1 Warranty Period	45
7.2 Warranty Card	45
7.3 Warranty Conditions	45
7.4 Scope of Warranty	46
8 Contact	47

Notes:

The pictures in this manual are for reference only, please be subject to the real product.

1 Symbols

	Caution! - Failure to observe a warning indicated in this manual may result in minor or moderate injury
	Danger of high voltage and electric shock!
	Danger of hot surface!
	Product should not be disposed as normal household waste.
	This side up- The package must always be transported, handled and stored in such a way that the arrows always point upwards.
	Components of the product can be recycled.
	Fragile-The package/product should be handled carefully and never be tipped over or slung.
	Stack limitation 6 units of identical packages that may be stacked in maximum.
	Keep dry – The package/product must be protected from excessive humidity and must accordingly be stored under cover.
	CE Mark
	Residual voltage exists in the inverter; the inverter cannot be maintained within 5 minutes until the capacitor is fully discharged

units

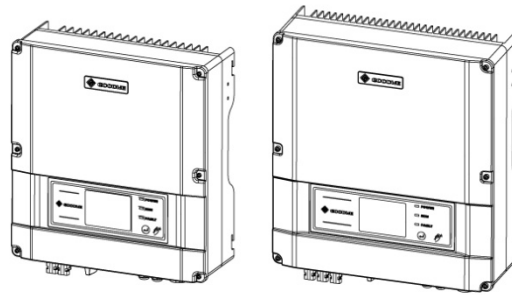

1.5-3KW

4-4.6KW

2 Safety

SS series inverter of Jiangsu GoodWe Power Supply Technology Co.,Ltd. (hereinafter referred to as GoodWe) strictly conforms to related safety rules in design and test. As electric and electronic equipment, Safety Regulation shall be followed during installation and maintenance. Improper operation may bring severe damage to the operator, the third party and other properties.

- ▶ The installation and maintenance of the inverters must be performed by qualified personnel only in compliance with national and local standards and regulations.
- ▶ Before installation and maintenance, DC input and AC output of the inverter should be cut off beforehand and the inverter cannot be touched within 10 minutes after power cut-off in case of electric shock.

- ▶ Partial temperature of the inverter may exceed 60°C during operation, please do not touch in case of scalding.
- ▶ All electric installation should conform to local electric standard and permission has to be obtained from local power supply department before synchronization by qualified personnel.
- ▶ Children must be kept away from inverters.
- ▶ Please do not open the front cover of inverter. Apart from wiring terminal, touching or changing components without authorization may cause damage to people and inverters. GoodWe may deny the obligation of warranty service accordingly.
- ▶ Static electricity may damage electronic components and proper measures shall be adopted to avoid static electricity.
- ▶ The output voltage of proposed PV array should be lower than the inverter maximum rated input voltage; otherwise, GoodWe will not undertake any obligations and warranty services.

3 Installation

3.1 Mounting Instruction









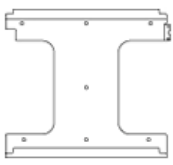
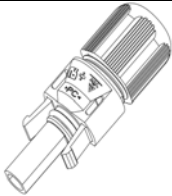
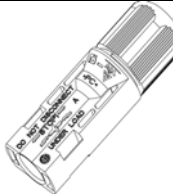

- A** In order to achieve optimal performance, the ambient temperature should be lower than 45 °C.
- B** For the convenience of checking the LCD display and possible maintenance activities, please install the inverter at eye level.
- C** Inverters should NOT be installed near inflammable and explosive items. Any electro-magnetic equipment should be kept away from installation site.
- D** Product label and warning symbol shall be clear to read after installation.

3.2 Unpacking

When you receive GoodWe inverter, please check if there is any visible external damage on the inverter or any accessories. Please also check if there is anything missing according to the list below.

Inverter	1
Wall-mounted bracket	1
Lock Plate	1
Positive DC Plug (GW1500-SS)	1
Negative DC Plug (GW1500-SS)	1
Positive DC Plug (GW2000-SS / GW3000-SS)	2
Negative DC Plug (GW2000-SS / GW3000-SS)	2
Positive DC Plug (GW3600S-UK/DK)	3
Negative DC Plug (GW3600S-UK/DK)	3

Positive DC Plug (GW4000-SS / GW4600-SS) 3
 Negative DC Plug (GW4000-SS / GW4600-SS) 3
 Unlock Tool for DC Plug 1
 AC Plug 1
 USB Data Cable 1
 Expansion Bolt 7
 Flat Head Screw for Lock Plate and RS485 Cover..... 5
 User Manual 1
 Warranty Card 1

 Wall-mounted Bracket	 Positive DC Plug	 Negative DC Plug	 Unlock Tool for DC Plug
 AC Plug	 USB Data Cable	 Expansion Bolt	 Lock Plate
 Flat Head Screw	 User Manual	 Warranty Card	 Inverter

3.3 Equipment Installation

3.3.1 Selecting the installation position

Installation position should be selected based on the following aspects:

- ▶ The installation method and mounting location must be suitable for the inverter's weight and dimensions.
- ▶ Mount on a solid surface.
- ▶ Select a well ventilated place sheltered from direct sun radiation.
- ▶ Install vertically or tilted backward by max 15°. The device cannot be installed with a sideways tilt. The connection area must point downwards.

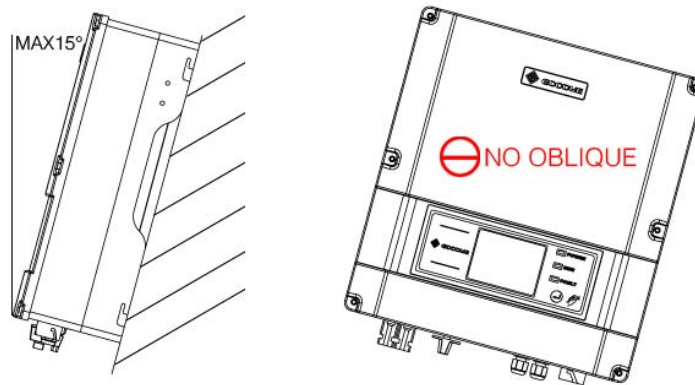

Figure 3.3.1-1

- ▶ In consideration of heat dissipation and convenient

dismantlement, the minimum clearances around the inverter should be no less than the following value:

Upward	300mm
Downward	500mm
Front	300mm
Both sides	200mm

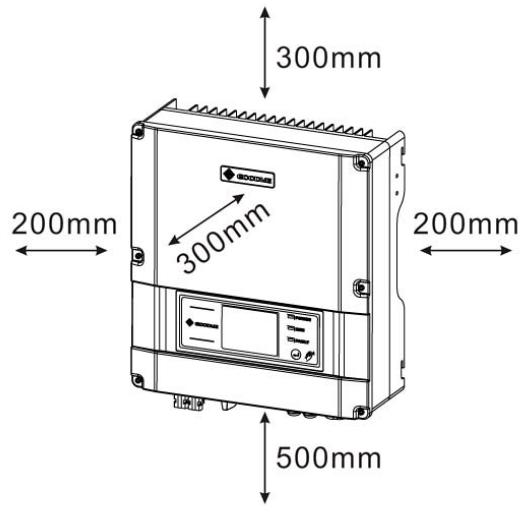

Figure 3.3.1-2

3.3.2 Mounting Procedure

- A Use the wall-mounted bracket as a template and drill 7 holes on the wall, 10 mm in diameter and 80 mm deep.

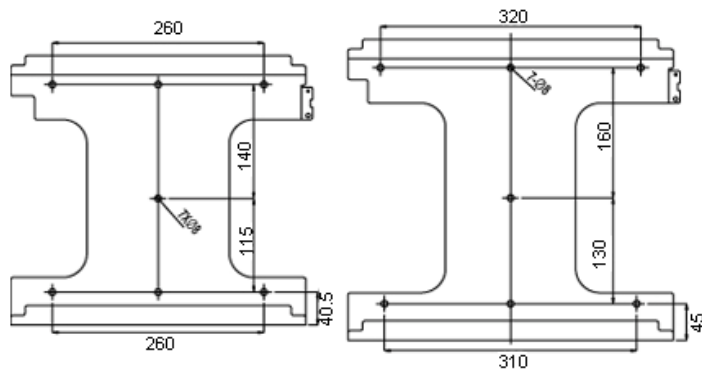

Figure 3.3.2-1

- B** Fix the wall mounting bracket on the wall with the expansion bolts in accessory bag.
- C** Carry the inverter by holding the groove on the heat sink.

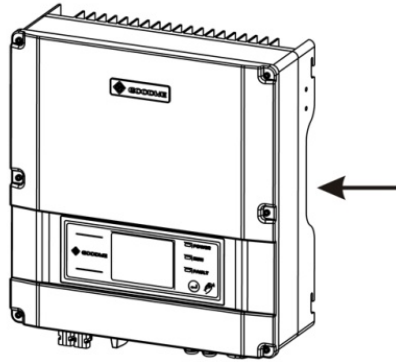

Figure 3.3.2-2

- D** Place the inverter on the wall-mounted bracket (as illustrated

below).

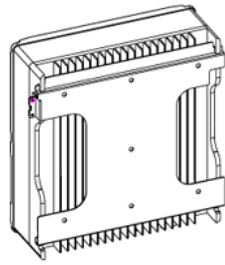

Figure 3.3.2-3

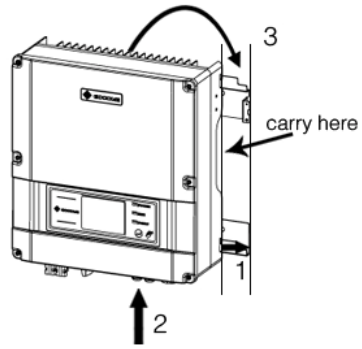

Figure 3.3.2-4

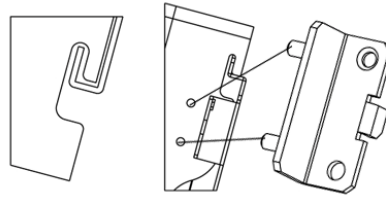

Figure 3.3.2-5

E Insert lock plate into two holes in the heat-sink, then fix the inverter with a padlock and screw M3x8

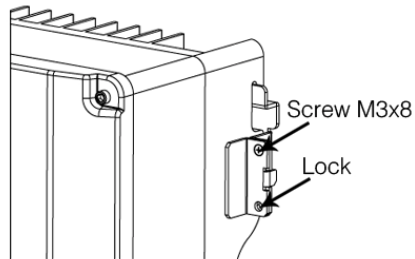

Figure 3.3.2-6

3.4 Electrical Connection

You must comply with the connection requirement of local regulations.

The inverter is integrate with an RCMU according to VDE0126-1-1/A1. It monitors residual current from the solar module to grid side of inverter. The inverter can automatically differentiate between fault current and normal capacitive leakage currents.

3.4.1 Connection to grid (AC side Connection)

- A** Check the grid (utility) voltage and frequency at the connection point of the inverter. It should be 230VAC (or 220VAC), 50/60Hz, and single phase.
- B** Disconnect the breaker or fuse between PV-Inverter and utility.
- C** Connect the inverter to the grid as follows:
 - ▶ Switch off the AC Breaker.
 - ▶ Disassemble female connector of the AC wire connector and connect AC wires to connection socket as indicated.

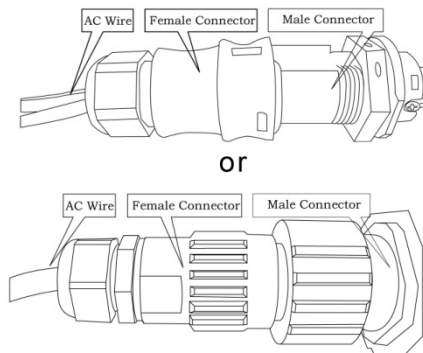



Figure 3.4.1-1

- ▶ Insert Line wire to Pin 1, Neutral wire to Pin 2 and Ground wire to Pin 

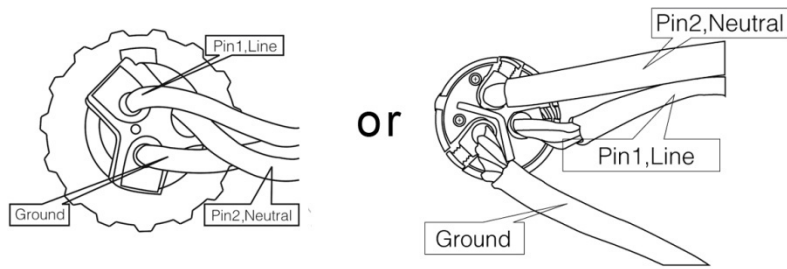

Figure 3.4.1-2

- ▶ After fastening all screws, reassemble the female connector of the AC wire connector.
- ▶ Connect the female connector of the AC wire connector to the Male connector on the inverter.

D Specifications of the AC wires:

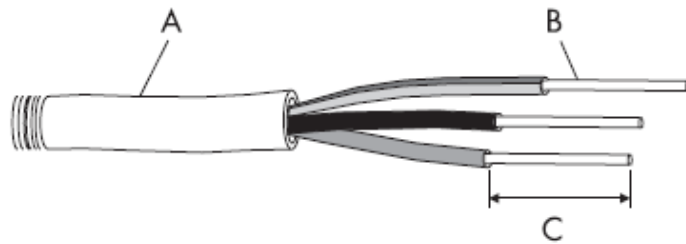

Figure 3.4.1-3

Depiction	Size
-----------	------

A External diameter of the wire	12mm-25mm
B Sectional area of conducting materials	Max.6mm ²
C Length of bare wire	Approx.10mm

E AC output connection diagram

Please tighten the screw with a screw driver until the head of the screw is inside the connector. Otherwise the wire could be loose.

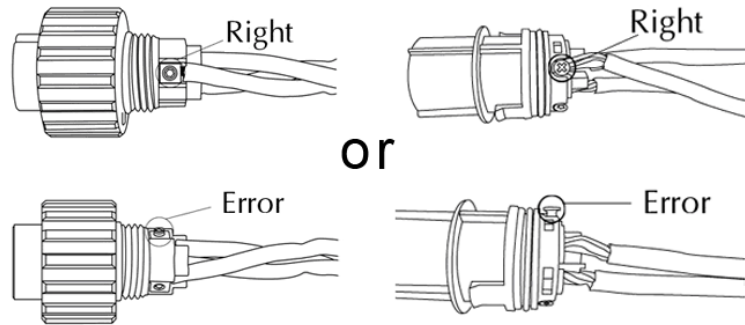
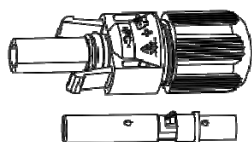

Figure 3.4.1-4

3.4.2 DC side connection

- A** Make sure the maximum open circuit voltage (V_{oc}) of each PV string does not exceed the inverter input voltage V_{max} under any condition.
- B** Use Multi-contact connectors for PV array terminals.
- C** Connect the positive and negative terminals of the PV panel to corresponding terminals on the Inverter. The DC terminal on each Inverter can bear 20A DC current.



Female side connector (PV+)

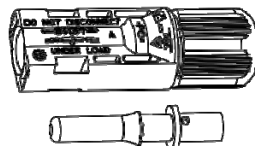

Male side connector (PV-)

Both types of connectors must be equipped in pair strictly according to above graphs

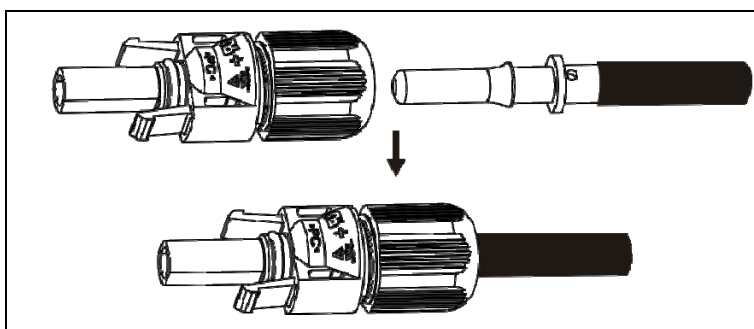
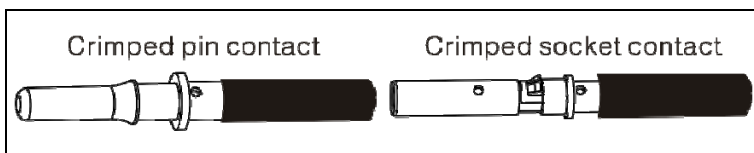
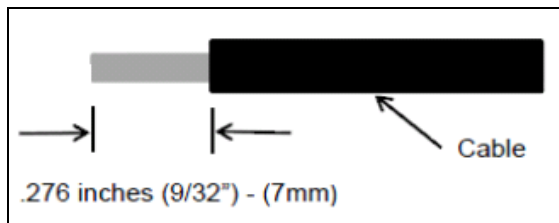

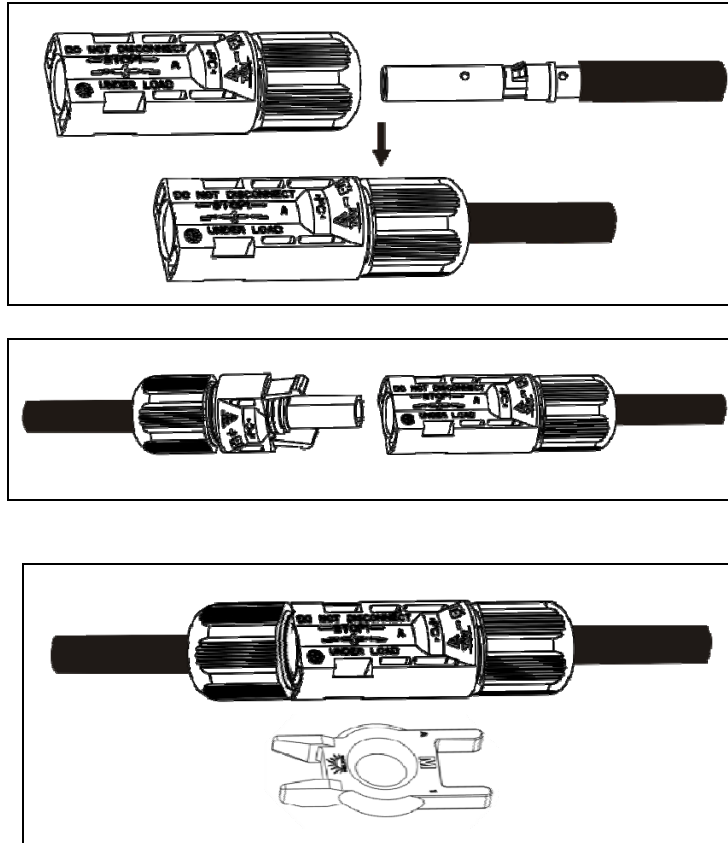

Figure 3.4.2-1 Separated by Ring tool

Regarding the inverter equipped with DC switch, please ensure the switch is in "OFF" position before connecting the inverter with PV panels. Then switch to "ON" when connecting job is done.

 Caution:

- ▶ Before connecting the PV panels, please ensure the plug connectors have the correct polarity. Incorrect polarity connection could permanently damage the unit.

- ▶ Checks short-circuit current of the PV string. The total short-circuit current of the PV string cannot exceed the inverter's maximum DC current.
- ▶ High voltage exists when the PV panel is exposed to the sun. Please secure the terminal connection, and do NOT touch any exposed components in case of electric shock.

3.4.3 RS485 Communication

RS485 interface is used for multipoint communication. EzLogger can monitor and communicate with 50 inverters at the same time. But the maximum length of the cable should not exceed 1000 m. All the inverters, which communicate through one cable, should use provided RS485 interface (a piece of 10# cable is recommend to be connected for waterproofing without RS485 cable connection). The typical inverter connection graph through RS485 is shown below.

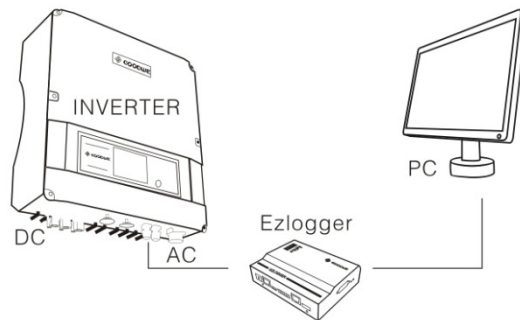

Figure 3.4.3-1

The graph below shows the monitoring system connection, in which inverters' multipoint communication can be realized through RS485 interface. The software "EzExplorer" used in PC end can realize real-time monitoring of 16 EzLoggers at the same time.

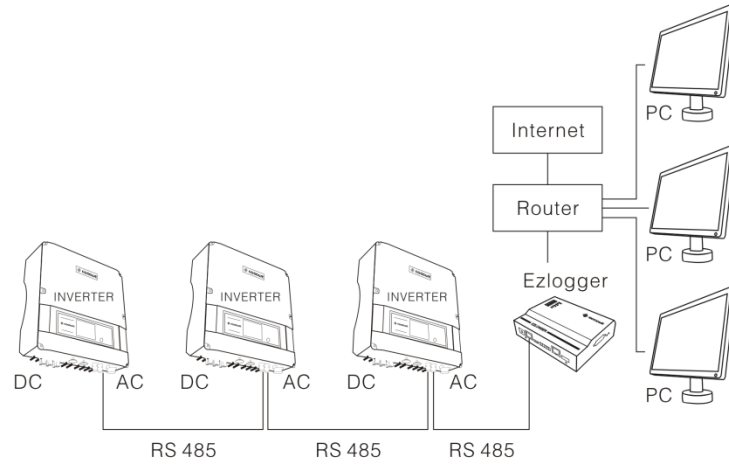
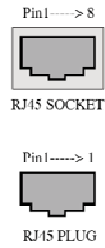

Figure 3.4.3-2

Pins of RS485 of GoodWe SS series:

Pin1-----TX_RS485A	
Pin2-----TX_RS485B	
Pin3-----RX_RS485A	
Pin4-----GND	
Pin5-----GND	
Pin6-----RX_RS485B	
Pin7-----+7V	
Pin8-----+7V	

A Connection procedure:

- a.** Screw off the RS485 cover;
- b.** Remove the screw cap of the cable gland;
- c.** Remove one-hole sealing ring;
- d.** Put RS485 cable through the components in this order:
screw cap, one-hole sealing ring, gland body;
- e.** Compress the crystal head and insert it into corresponding interface;
- f.** Fasten the waterproof of RS485 Cover;
- g.** Fasten the screw cap of the cable gland.

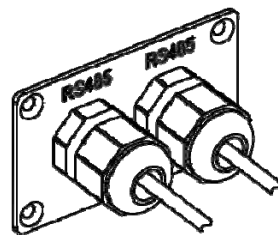

Figure 3.4.3-3

- B** RS485 cable is composed by eight wires with different colors.
Chop the envelope outside to expose the eight wires, then straighten the end of every wire, and put them in order.

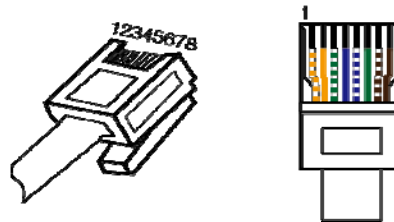

Figure 3.4.3-4

- C** The connection between crystal connectors and RS485 wires must be corresponding with each other, as shown in the table below.

The number of the pins of crystal connector	Color of the RS485 wires
	Orange and white
	Orange
	Green and white
	Blue
	Blue and white
	Green
	Brown and white
	Brown

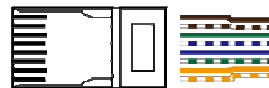

Figure 3.4.3-5

- D** Plug the eight wires into corresponding slots of the crystal connector, and then fix them up using a 485 wire crimper.

- E** Connect the other end of RS485 cable to crystal connector according to procedure 3 and 4.
- F** The inverter can communicate with an EzLogger through RS485 cable. When EzLogger is connected to PC via Ethernet or USB interface, the inverter can communicate with PC directly.

3.4.4 Wireless Communication

The wireless communication function is not compatible with the 485 communication function.

An EzBee is needed for wireless function. For installation and detail information of wireless function please refer to User Manual of EzBee.

The typical inverter connection graph through Wireless is shown below.

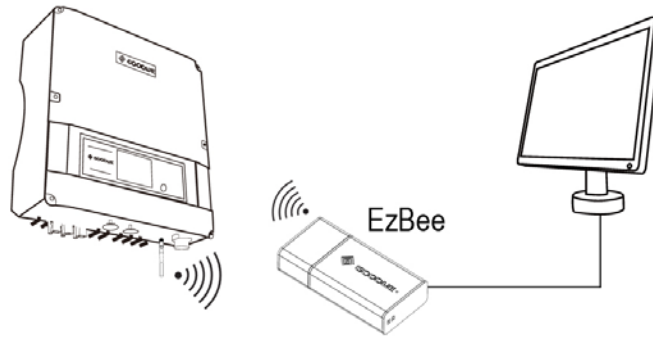

Figure 3.4.4-1

One Ezbee could monitor up to 50pcs of inverter. The graph

below shows the multi-inverters monitoring system connection through Wireless function.

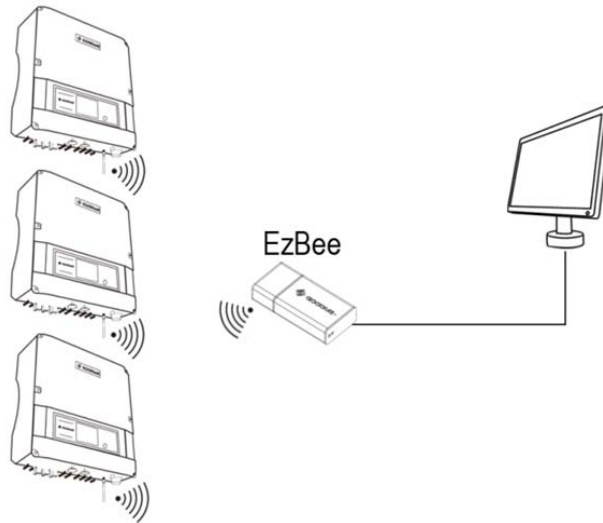

Figure 3.4.4-2

3.4.5 USB Communication

USB data cable must be connected as below

- A** Take off the USB socket cover
- B** Insert USB cable as the arrow pointed out

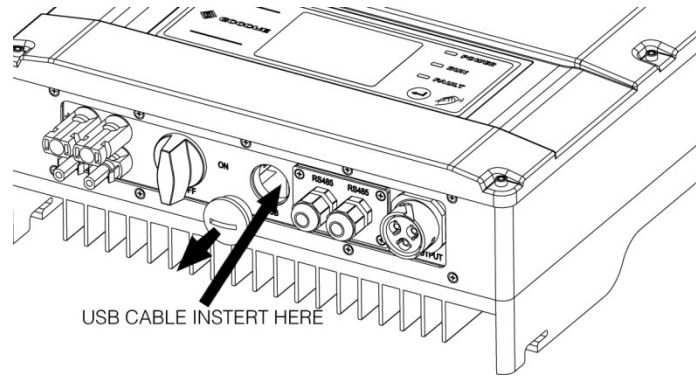

Figure 3.4.4-1

3.5 Troubleshooting

In most situations, the Inverter requires very little maintenance. However, if the Inverter is not able to work properly, please refer to the following instructions before calling your local dealer:

- ▶ Should any problems arise, the red (Faulty) LED indicator on the front panel lights up and the LCD screen will display relevant information. Please refer to the following table for a list of error message and associated solutions.

	Display	Possible actions
System Fault	Isolation Failure	<ol style="list-style-type: none"> 1. Check the impedance between PV (+) & PV (-) and make sure the PV-Inverter is earthed. The impedance value must be greater than 2MΩ. 2. Contact local service office for help if the problem still exists.

	Ground I Failure	<ol style="list-style-type: none"> 1. The ground current is too high. 2. Unplug the inputs from the PV generator and check the peripheral AC system. 3. When the problem is cleared, reconnect the PV panel and check the Inverter status. 4. Contact local service office for help if the problem still exists.
	Vac Failure	<ol style="list-style-type: none"> 1. The PV Inverter will automatically restart within 5 minutes if the grid returns to normal. 2. Make sure grid voltage is in conformity with the specification. 3. Contact local service office for help if the problem still exists.
	Fac Failure	<ol style="list-style-type: none"> 1. The PV Inverter will automatically restart within 5 minutes if the grid returns to normal. 2. Make sure grid frequency is in conformity with the specification. 3. Contact local service office for help if the problem still exists.
	Utility Loss	<ol style="list-style-type: none"> 1. Grid is not connected. 2. Check grid connection cables. 3. Check grid usability.
Inverter fault	PV Over Voltage	<ol style="list-style-type: none"> 1. Check whether the PV open voltage is higher or too close to the maximum input voltage. 2. If the problem still exists when PV voltage is less than the maximum input voltage, contact local service office for help.
	Consistent Failure	<ol style="list-style-type: none"> 1. Disconnect PV (+) or PV (-) from the input and restart the PV Inverter. 2. If the problem still exists, contact local service office for help.

Over Temperature	<ol style="list-style-type: none"> 1. The internal temperature is higher than normal value specified. 2. Reduce ambient temperature. 3. Move the inverter to a cool place. 4. If the problem still exists, contact local service office for help.
Relay-Check Failure	<ol style="list-style-type: none"> 1. Disconnect all PV (+) or PV (-). 2. Wait for a few seconds. 3. After the LCD switches off, reconnect and check again. 4. If the message appears again, contact local service office for help.
DC Injection High	
EEPROM R/W Failure	
SCI Failure	
DC Bus High	
Ref 2.5V Failure	
GFCI Failure	

- ▶ If there is no display on the panel, please check PV-input connections. If the voltage is higher than 125V, contact local service office for help.
- ▶ When sunlight is insufficient, the PV Inverter may continuously start up and shut down automatically due to insufficient power generated by the PV panel. If the problem remains, please contact the local service office.

4 System Operation

4.1 Display

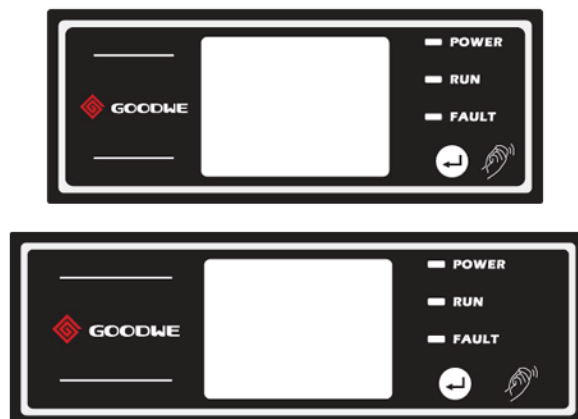

Figure 4.1-1

4.2 Indicator Lights

- ▶ Yellow: light on indicates the inverter is electrified; light off means the inverter is not electrified.
- ▶ Green: light on indicates the inverter is feeding power; light off means the inverter is not generating power at the moment. Slow flicking (1HZ) indicates the inverter is self-checking while fast flicking (5HZ) indicates inverter finishes self-checking and is ready for grid integration.
- ▶ Red: light on indicates abnormal conditions appear; light off means there is no abnormal condition.

4.3 LCD Display

A The schematic of display screen is shown below:

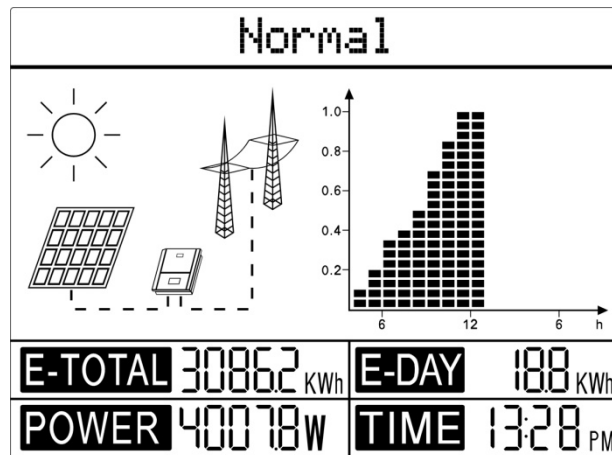

Figure 4.3-1

B Display area

Display area is divided into top area, middle area and bottom area.

Top area: displaying status information.

- ▶ This area displays the status information. “Waiting” indicates the inverter is standby for power generation; “Checking 30S” (checking time based on safety varies from country to country) indicates the inverter is self-checking, counting down and preparing for power generation; “Normal” indicates the inverter is generating power; if any condition of the system is abnormal, the screen will display error message, please refer to Table 4.4-1.
- ▶ Through key operation, the screen can display different information such as operation parameters and power generation

status in this area. There are two levels of menus, and the flow chart of first level menu is shown below:

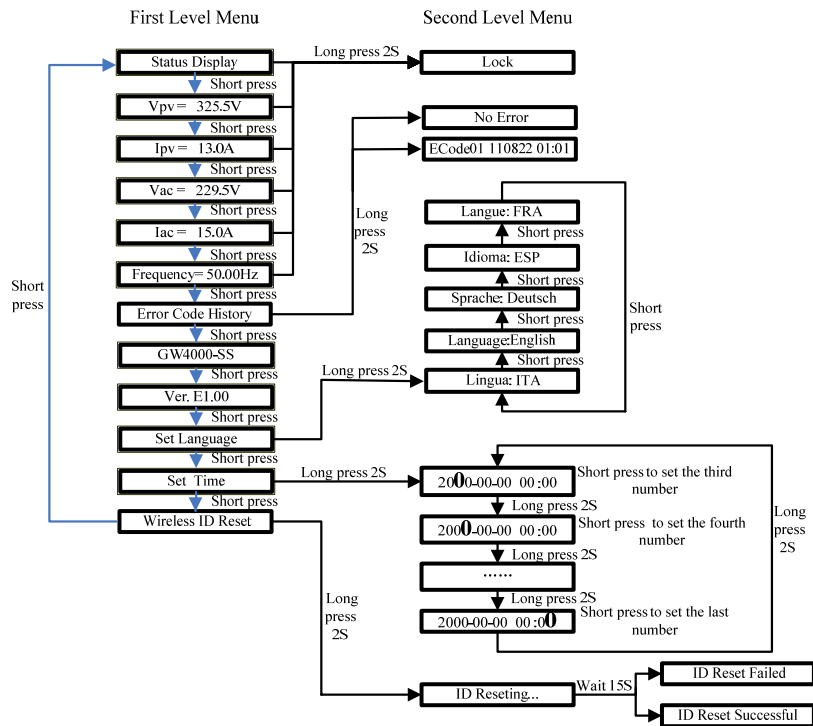

Figure 4.3-2

- ▶ Menu display can be controlled by pressing the key; Holding the key for a while will enter into the submenu.

Middle area, Left:

- ▶ The electrical connection status on DC side and AC side are represented by dashed line and full line. Flashing dashed line on DC side indicates PV panel is feeding power to the inverter;

Nothing shows on AC side means grid is not available; full line on AC side means grid is available, but the inverter is not generating power at the moment; flashing dashed line on AC side indicates the inverter is feeding power to the grid network.

Middle area, Right:

- ▶ In this area, histogram is used to represent the hourly average power generation from 4 a.m. to 8 p.m. at the same day. The average power at full column represents the nominal power of system.

Bottom area:

Bottom area displays total power generation, daily power generation, and power generated at present and time information, described as follow:

Part	Description
E-TOTAL	Gross power generated from the first time use of inverter. The initial unit is “kWh”; When power generation exceeds 9999.9kWh, the unit changes to “MWh”.
E-DAY	Power generated the same day
POWER	Instant power generation of the system
TIME	Current system time

C Key operation:

There are 2 modes of key operation:

Short press, Long press 2S.

D Key operation and LCD description:

- ▶ Key operation is mainly for language and time setting. Clients can also find the information they concern through key operation.
- ▶ The menu in LCD display area has two levels, you can hold the key to enter second-level menu; long press the key 2S to lock the current interface if there is no second-level menu.
- ▶ In all levels of menu, it will automatically enter the first item of the first level menu if no action is taken within 20S, meanwhile, the modified data will be stored into internal memory.

E Menu Introduction

- ▶ When PV panel is feeding power to the inverter, the screen shows the first-level menu.
- ▶ Initial display is the first interface of the first-level menu and the interface displays current state of the system. It shows “Waiting” in the initial state; it shows “Normal” during power generation mode; if there is something wrong with the system, error message is shown. Please see 4.4 for fault code.
- ▶ Short press the key once to enter V_{pv} menu which displays the PV voltage in“V”.
- ▶ Short press the key once to enter I_{pv} menu which displays the PV current in“A”.
- ▶ Short press the key once to enter V_{ac} menu which displays the grid voltage in“V”.
- ▶ Short press the key once to enter I_{ac} menu which displays the grid current in“A”.

- ▶ Short press the key once to enter Frequency menu which displays the grid frequency in“Hz”.
- ▶ Long press the key for 2S will enter the second-level menu of error detection history, the last three inverter error records will be shown by short pressing the key in the second-level menu, which includes error code (ECODEXX), error time (e.g. 110316 15:30). Error code can be found in Table. 4.4-2. The LCD backlight will be off without any operation within 20S, LCD display will automatically return to main menu.
- ▶ Short press the key once into ModelName menu under which submenu can be found.
- ▶ Short press the key once to enter the software version menu which shows the current software version used. The LCD backlight will be off without any operation within 20S, LCD display will automatically return to main menu.
- ▶ Short press the key once to enters language display menu. Press the button for 2S to enter the second level menu. The circulatory submenu including five languages can be found. The language can be chosen by short pressing the key. The inverter will store the chosen language without any action within 20S and LCD display will automatically return to main menu when the backlight is off.
- ▶ Short press the key once to enter time display menu which is used to set the current time. Long press the key for 2S to enter the submenu to set the time of the inverter. The initial display is

“2000-00-00 00: 00”, in which the first four numbers represent the year (e.g. 2000~2099); the fifth and the sixth number represent the month (e.g. 01~12); the seventh and the eighth represent the date (e.g. 01~31), the ninth number will be flicking firstly and number“0”, “1”, “2”can be chosen by shortly pressing the button. Then hold the key for 2S to set the tenth number. Number 0-9 can be chosen by short pressing the key. “Minute” can be set with the same steps as the “hour”. The inverter will store the time without any action in 20S and LCD will automatically return to main menu when the backlight is off.

- ▶ Short press the key once to enters wireless ID reset display menu. Press the button for 2S to put wireless ID under resetting. 15S later the result of ID resetting will be displayed. 5S later it returns to main menu and the backlight becomes off.
- ▶ Long press the key 2S in the menu with no submenu, LCD will display “Lock” and then this menu will be locked after 1S.
- ▶ In order to check Vpv value, enter Vpv menu first, long press the key 2S, the screen will display “Lock” first and Vpv value afterwards.
- ▶ The locked menu can only be unlocked under system mode switching, fault occurrence or key operation.

F Normal Start and Operation Display.

- ▶ When the input voltage reaches inverter turn-on voltage, LCD starts to work, the yellow light is on, LCD displays “waiting”,

more information will be displayed within a few seconds. If the inverter is connected to the grid, “Checking 30” will be shown up in 2S, counting down from 30S, when it shows “00S” you can hear the relay triggered 4 times, LCD displays “Normal” afterwards. The instant power output will be shown at the left bottom of LCD.

G Voice Control

When knock the machine cover around the inverter screen, the first-level menu can be flipped over and the LCD backlight turns on. However, it is not able to enter LCD second-level menu through voice control.

4.4 Error message

An error message will be displayed on LCD interface when a disturbance occurs.

Table 4.4-1 Description of Error Message

Error message	Description
Utility Loss	Grid disconnected
Fac Failure	Grid frequency no longer within permissible range
Consistent Failure	Machine parameter consistent fault
Device Failure	Device internal fault
PV Over Voltage	Overvoltage at DC input
Over Temperature	Overtemperature on the case

Isolation Failure	Ground insulation impedance is too low
Ground I Failure	Overhigh ground leakage current
Relay-Check Failure	Relay self-checking failure
DC Injection High	Overhigh DC injection
EEPROM R/W Failure	Memory chip failure
SCI Failure	Internal communication failure
DC Bus High	Overhigh BUS voltage
Ref 2.5V Failure	2.5V reference voltage failure
AC HCT Failure	Output current sensor failure
GFCI Failure	Detection circuit of ground leakage current failure
Vac Failure	Grid voltage no longer within permissible range

Table 4.4-2 Description of Error Code

Error Code	Description
01	Communication between microcontrollers is failing
02	EEPROM cannot be read or written
03	The master-frequency is out of tolerable range
04	The slave-frequency is out of tolerable range
05	NA
06	NA
07	Relay is Fail
08	NA
09	Different value between Master and Slave for grid voltage
10	Different value between Master and Slave for grid frequency
11	NA

12	Different value between Master and Slave for Fac, Uac
13	The DC injection check for grid Current is fail
14	Isolation resistance of PV-plant out of tolerable range
15	Master-grid voltage measurement-value out of tolerable range
16	Fan Lock
17	Pv input voltage is over the tolerable maximum value
18	NA
19	Over temperature fault
20	NA
21	Dc bus fault
22	Ground current is too high
23	Grid voltage =0
24	NA
25	Device Fault
26	Dc Bus voltage is too high.
27	NA
28	Different value between Master and Slave for GFCI
29	Different value between Master and Slave for output DC current
30	The 2.5V reference inside are abnormal
31	The output DC current sensor is abnormal
32	The GFCI detecting circuit is abnormal

4.5 ID RESET

Keep single-pressing operation button until the LCD display “Wireless ID Reset”, then Long press the button for 2S, until LCD display “ID Resetting ...”, stop pressing and await the screen show “ID Reset Successful” or “ID Reset Failed”.

NOTE: This function is only available for inverters which support wireless function. When the wireless monitoring device can't connect to the inverter, you can try to use the ID reset function.

5 Technical Parameters

Table 5.1 GW1500-SS, GW2000-SS, GW3000-SS

Model Name	GW1500-SS	GW2000-SS	GW3000-SS
DC input data			
Max. PV-generator power [W]	1800	2300	3200
Max. DC Voltage [V]	450	500	500
MPPT voltage range [V]	125~450	125~450	125~450
Turn on DC Voltage [V]	125	125	125
Turn off DC Voltage [V]	90	90	90
Max. DC work current [A]	12	15	18
Max.PV array short current[A]	15	18	20
Number of DC connection	1	2	2
Number of MPP trackers	1	1	1
DC-connection	MC IV Connector		
Turn on power [W]	5	5	5
Night power[W]	0	0	0
Output data			
Nominal AC power	1500W	2000W	3000W
Max.AC power	1650W	2000W	3000W
Max.output current[A]	8	10	15
Nominal output voltage range	According to VDE-AR-N 4105, VDE0126-1-1/A1, AS4777.2./3, RD1699, G83/1, CEI 0-21,		
AC grid frequency	According to VDE-AR-N 4105, VDE0126-1-		

	1/A1, AS4777.2./3, RD1699, G83/1, CEI 0-21,		
THD(AC output current)	<1%		
Power factor	~1(Nominal power)		
AC Connector	Single phase with Clamps		
Efficiency			
Max. efficiency	97.0%	97.0%	97.0%
Euro efficiency	>96%	>96%	>96.5%
MPPT adaptation efficiency	>99.5%	>99.5%	>99.5%
Safety equipment			
DC reverse polarity protection	Integrated(with diode)		
Leakage current monitoring unit	Integrated		
AC short protection	Integrated		
DC switch-disconnector	Option		
Islanding protection	AFD		
Grid Monitoring	According to VDE-AR-N 4105, VDE0126-1-1/A1, AS4777.2./3, RD1699, G83/1, CEI 0-21,		
Normative reference			
EMC compliance	According to EN 61000-6-1,EN 61000-6-2,EN 61000-6-3,EN 61000-6-4		
Safety compliance	According to IEC62109-1, AS3100		
General data			
Dimensions (WxHxD) [mm]	330*350*125		
Net Weight [kg]	12	13	

Housing	For outdoor and indoor
Mounting information	Wall bracket
Operating temperature range	-20~60°C (up 45°C derating)
Relative humidity	0~95%
Site altitude	2000m
IP protection type	IP65
AC Over voltage category	Category III
DC Over voltage category	Category II
Protective Class	Class 1
Topology	Transformerless
Cooling concept	Nature Convection
Noise level	<25dB
Display	4" LCD
Data communication	USB 2.0; 485(wireless optional)
Standard warranty	5/10/15/20/25(optional)

Table 5.2 GW4000-SS, GW4600-SS

Model Name	GW4000-SS	GW4600-SS
DC input data		
Max. PV-generator power [W]	4600	5400
Max. DC Voltage [V]	580	580
MPPT voltage range [V]	125~550	125~550
Turn on DC Voltage [V]	125	125
Turn off DC Voltage [V]	90	90
Max. DC work current [A]	20	20
Max.PV array short current[A]	27	27
Number of DC connection	3	3
Number of MPP trackers	1	1
DC-connection	MC IV or HC IV-connector	
Turn on power [W]	5	5
Night Power [W]	0	0
Output data		
Nominal AC power	4000W	4600W
Max.AC power	4400W	5100W
Max.output current [A]	22	25
Nominal output voltage range	According to VDE-AR-N 4105, VDE0126-1-1/A1, AS4777.2./3, RD1699, CEI0-21, G59/2	
AC grid frequency	According to VDE-AR-N 4105, VDE0126-1-1/A1, AS4777.2./3, RD1699, CEI0-21, G59/2	

THD(AC output current)	<2%	
Power factor	~ 1(Nominal power)	
AC Connector	Single phase With Clamps	
Efficiency		
Max. efficiency	97.8%	97.8%
Euro efficiency	>97.4%	>97.4%
MPPT adaptation efficiency	>99.5%	>99.5%
Safety equipment		
DC reverse polarity protection	Integrated(with diode)	
Leakage current monitoring unit	Integrated	
AC short protection	Integrated	
DC switch -disconnecter	Option	
Islanding protection	AFD	
Grid Monitoring	According to VDE-AR-N 4105, VDE0126-1-1/A1, AS4777.2./3, RD1699, CEI0-21, G59/2	
Normative reference		
EMC- compliant according to	EN 61000-6-1,EN 61000-6-2,EN 61000-6-3,EN 61000-6-4	
Safety compliance	According to IEC62109-1, AS3100	
General data		
Dimensions (WxHxD) [mm]	390*417*142	
Net Weight [kg]	18	
Housing	For outdoor and indoor	

Mounting information	Wall bracket
Operating temperature range	-20~60°C (up 45°C derating)
Relative humidity	0~95%
Site altitude	2000m
IP protection type	IP65
AC Over voltage category	Category III
DC Over voltage category	Category II
Protective Class	Class I
Topology	Transformerless
Cooling concept	Natural convection
Noise level	<25dB
Display	4"LCD
Data communication	USB2.0; 485(Wireless/Bluetooth optional)
Standard warranty	5/10/15/20/25(optional)

Table 5.3 GW3600S-DK/UK

Model Name	GW3600S-DS/UK
DC input data	
Max. PV-generator power [W]	4200
Max. DC Voltage [V]	580
MPPT voltage range [V]	125~550
Turn on DC Voltage [V]	125
Turn off DC Voltage [V]	90
Max. DC work current [A]	20
Max.PV array short current[A]	27
Number of DC connection	3
Number of MPP trackers	1
DC-connection	MC IV connector
Turn on power [W]	<5
Night Power [W]	0
Output data	
Nominal AC power	3600W
Max.AC power	4000W
Max.output current [A]	16
Nominal output voltage range	G83/1(For UK); VDE0126-1-1/A1 and EN 50438(For DK)
AC grid frequency	G83/1(For UK); VDE0126-1-1/A1 and EN 50438(For DK)

THD(AC output current)	<1%
Power factor	~ 1
AC Connector	Single phase With Clamps
Efficiency	
Max. efficiency	97.6%
Euro efficiency	>97.4%
MPPT adaptation efficiency	>99.5%
Safety equipment	
DC reverse polarity protection	Integrated(with diode)
Leakage current monitoring unit	Integrated
AC short protection	Integrated
DC switch -disconnecter	Option
Islanding protection	AFD
Grid Monitoring	G83/1(For UK); VDE0126-1-1/A1 and EN 50438(For DK)
Normative reference	
EMC- compliant according to	EN 61000-6-1, EN 61000-6-2, EN 61000-6-3, EN 61000-6-4
Safety compliance	According to IEC62109-1
General data	
Dimensions (WxHxD) [mm]	390*417*142
Net Weight [kg]	18
Housing	For outdoor and indoor

Mounting information	Wall bracket
Operating temperature range	-20~60°C (up 45°C derating)
Relative humidity	0~95%
Site altitude	2000m
IP protection type	IP65
AC Over voltage category	Category III
DC Over voltage category	Category II
Protective Class	Class I
Topology	Transformerless
Cooling concept	Natural convection
Noise level	<25
Display	4"LCD
Data communication	USB2.0; RS485 (Wireless/Bluetooth optional)
Standard warranty	5/10/15/20/25(optional)

6 Certificates



7 Warranty

7.1 Warranty Period

GoodWe provides standard warranty period of 5 years for SS series products (Warranty period begins from the date on purchase invoice). Additional provision will be subject to contract.

7.2 Warranty Card

Warranty card and purchase invoice should be properly kept within product warranty period. Meanwhile, the nameplate on products shall be clear to read. Otherwise GoodWe may deny the warranty service or only provide paid service.

7.3 Warranty Conditions

According to GoodWe product description and instruction, if a device becomes defective within warranty period, and it is proved that further functional performance is impossible due to product quality problem, the device will be, as selected by GoodWe:

- A** Return to the factory for maintenance;
- B** Onsite maintenance;
- C** Products Replacement (if the original model has stopped in production, GoodWe will provide a replacement device of equivalent value according to model and age.).

7.4 Scope of Warranty

Warranty declaration is excluded in the following situations:

- ▶ Products or fittings exceed warranty period (exclude the warranty extension agreement signed beforehand).
- ▶ Fault or damage due to improper operation without following user manual, product instruction, and relevant safety regulations.
- ▶ Insufficient ventilation of the unit
- ▶ Fault or damage due to improper installation, repair, change or removal by persons who are not authorized by GoodWe.
- ▶ Fault or damage due to unpredictable accidental factors, human errors or force majeure.
- ▶ Fault or damage which is not caused due to products quality problem.

8 Contact

If you have any enquiries or technical problems concerning GoodWe SS series inverter, please contact our customer services.

Add: No.189 Kun Lun Shan Road, Suzhou New District, Jiangsu, China (Jiangsu GoodWe Power Supply Technology Co., Ltd.)

Tel: + 86 512 6239 6771

Fax: + 86 512 6239 7972

E-mail: service@goodwe.com.cn

Website: www.goodwe.com.cn